

PROJECT TRAILER: TANDEM OF ROVER AND ASSOCIATED WAIN FOR LUNAR EXTENDED ROAMING.

Virtual Conference 19–23 October 2020

P. Weiss¹, T. Gobert¹, M. Peer¹, N. Singh¹, T. Chalal¹, T. Beurthey¹, B. Imhof², R. Davenport², R. Waclavicek², R. Sonsalla³, F. Cordes³, C. Schulz³, J. Babeland³ and M. Zwick⁴

¹ COMEX S.A., 36 Bvd des Océans, 13008 Marseille, France, p.weiss@comex.fr

² LIQUIFER Systems Group GmbH, Donandtstrasse 35, 28209 Bremen, Germany, barbara.imhof@liquiferspacesystems.com

³ DFKI GmbH Robotics Innovation Center, Robotics Innovation Center, Robert-Hooke-Straße 1, 28359 Bremen, Germany, roland.sonsalla@dfki.de

⁴ ESA - European Space Agency, Keplerlaan 1, 2201 AZ Noordwijk, Netherlands, Martin.Zwick@esa.int

ABSTRACT

TRAILER is a two-year project contracted by the European Space Agency ESA to test a novel architecture of robotic cooperation based on a tandem of two rovers for lunar surface exploration missions.

The future lunar GATEWAY can be considered as a “Base Camp” that will serve to perform human and robotic expeditions on the surface of the Moon. Astronauts and robots will work together to prepare the coming era of space exploration with missions to the lunar South Pole and other locations: robotic explorers will search for ISRU elements that could support a human presence on the surface. These *scouts* will be operated either from Earth or from GATEWAY; and they will need to perform certain tasks in autonomy.

The main objective of the TRAILER activity is to develop a rover system consisting of i) An agile and powerful rover (TRACTOR) equipped with high performance locomotion and navigation, local wireless transceiver, short-term energy storage, sample acquisition system, and ii) An active trailer (WAIN) equipped with limited locomotion and navigation, high power generation or storage and local wireless network that could assure lunar-earth communication and a scientific laboratory for sample collection and analysis. The TRAILER activity is under a contract by ESA and led by the Marseille-based company COMEX that develops the “WAIN”. The German Research Center for Artificial Intelligence Robotics Innovation Center (DFKI RIC) in Germany is responsible for simulations and development of the second robot, the “TRACTOR”. LIQUIFER Systems Group in Austria defines the mission and operation scenarios of the robotic tandem and planning. The TRAILER system will be tested in facilities at the

partner organizations in France, Germany and Austria.

1 INTRODUCTION

In March 2010 the US Lunar Reconnaissance Orbiter “rediscovered” the first robot to roam a surface beyond Earth: The Russian Lunokhod 1 rested on the Moon for 40 years before its final position could be located. On April 22, 2010 scientists at the University of California fired a laser at Lunokhod 1 and successfully received a return signal from its reflector. This 760 kg vehicle operated on the surface from November 1970 to September 1971 and performed more than 10 kilometers of exploration of the lunar surface; one year after the second manned mission to the Moon, Apollo 12. It worked on the surface of the Moon at the same time when the crew of Apollo 14 performed its lunar exploration - Astronauts and Robots have already “worked together” on the lunar surface! [1].

A new era of lunar exploration is about to start: The European Space Agency (ESA) is working with its international partners on the development of the lunar GATEWAY, the first permanent human outpost beyond Earth’s orbit. GATEWAY must be considered as a Base Camp that will serve to set-up missions on the surface of the Moon. Again, astronauts and robots will work together to prepare the coming era of space exploration with missions to the lunar South Pole and other locations. The main purpose of the TRAILER project is to develop and test a novel architecture of robotic exploration vehicles for coming lunar surface missions. A combination of a versatile rover that can dock and undock from a larger carrier vehicle might have several advantages in coming mission scenarios where on one hand large areas have to be traversed and on the other hand specific spots need to be explored - spots that might be hard to reach such as

craters with steep slopes, or permanently shadowed regions.

The main objective of the TRAILER project is to develop a compound rover system consisting of i) an agile and powerful rover equipped with high performance locomotion and navigation, local wireless transceiver, short-term energy storage, sample acquisition system, and ii) an active trailer equipped with limited locomotion and navigation, high power generation or storage and local wireless network that could assure lunar-earth communication and host a scientific laboratory for sample collection and analysis. Figure 1 illustrates the two main systems of the project: The Tractor and the Wain; each with their specific functionalities. The main objective of the activity is to test and demonstrate cooperation capabilities of both vehicle-systems; therefore, some functionalities such as sampling or sample analysis are reproduced in a simplified mock-up version only. In order to define the requirements for the TRAILER rover duo the consortium performed a literature survey of possible robotic surface operations. The ESA HERACLES mission concept was taken as potential reference scenario, which can be divided into three phases: 70 days of surface sampling (including control from crew on GATEWAY and ground), 1 year of surface mobility demonstration and up to 1 year of surface operations and relocation to a different landing site. The reference landing site is Schrödinger Crater (75.0°S 132.4°E) a 300 km diameter impact crater at lunar south pole / far side of the Moon. Landgraf, Carpenter and Sawada [2] give a possible scenario of surface operations, which is illustrated in

tential volcanic vent located inside the inner peak ring. From that landing site the rover-pair would traverse towards the slopes of the inner peak ring; potentially then extending to the outer peak rims with altitudes of up to 3 km from the crater's floor.

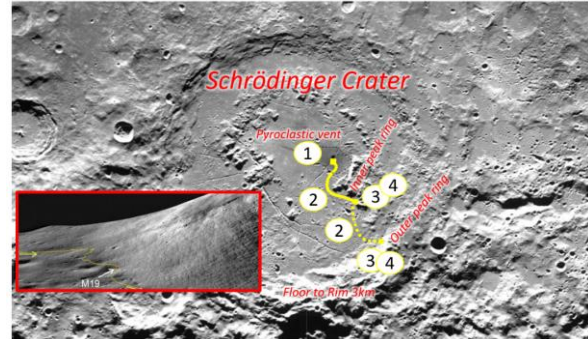

Figure 2: HERACLES mission scenario

For the following definition of a Mission Scenario four specific activities were defined: 1. Activation: Activation of the system, system checks 360° panoramic photograph, mission planning and set-up, systems check and rolling down the ramp of the lander. 2. Translation: Moving to the zone of interest (long traverses), local photo survey of the target zone, communications with MCC (GATEWAY or Ground). 3. Separation: undocking or docking to separate both vehicles, Tractor is sent to a specific zone to explore (crater, slope, rocks). 4. Exploration: Tractor takes close camera views, takes samples and communicates to Wain, Wain communicates with MCC and moves to a rendezvous point where both dock again, Tractor transfers sample that is analyzed

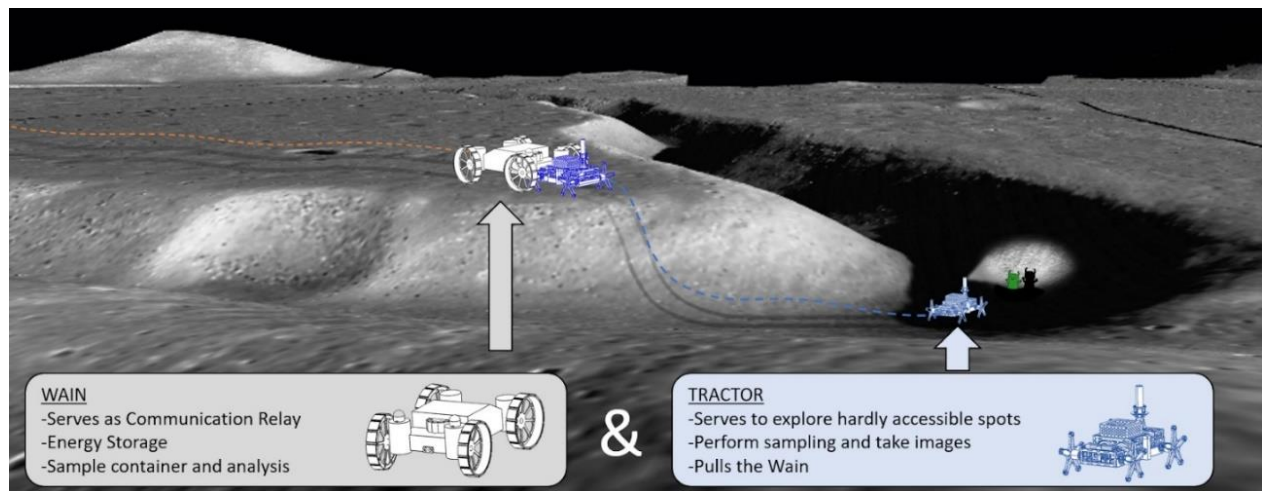

Figure 1: The TRAILER architecture

Figure 2. The scenario foresees landing with a robotic lander near Schrödinger G (75.4° S, 137.2° E) a po-

in the laboratory of Wain and Wain recharges the batteries of the Tractor. Figure 3 illustrates the four phases (also reported by the numbers in Figure 2).

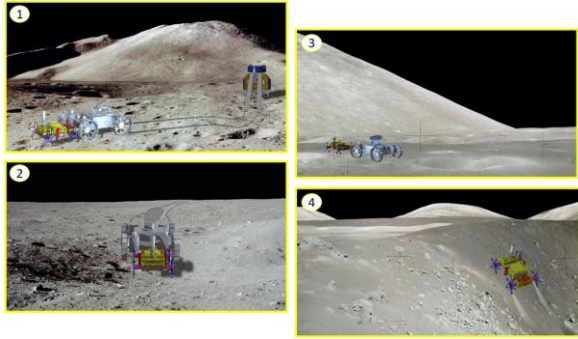

Figure 3: Different phases of the TRAILER system.

2 TRAILER OVERALL SYSTEM DESIGN

The objective of the project is to test lunar exploration based on a tandem of two rovers. The rovers travel large distances together over lunar surface and therefore need superior locomotion capabilities on the lunar surface. The concept comprises a small high mobile and powerful TRACTOR which can dock to a larger and also active WAIN rover. TRACTOR being the powerful traction rover in the system must be able to traverse rocky terrain and climb moderate slopes. In contrast WAIN is considered the supply system, holding the main power source, communication sub-system and scientific payloads with only limited mobility parameter. The idea is to gain an increased mobility by docking both systems together and implementing a load and tractive performance share between both rovers. This would be the set-up for traversal and exploration of larger distances and areas. In order to gain access to harder to reach locations, the TRACTOR can un-dock from WAIN and go for a detour while WAIN acting as supportive relay station and/or second mobile platform able to perform additional mission tasks. The general system architecture will make use of the communication infrastructure, as schematically drawn in Figure 4. The main communication link between ground control and the TRAILER system will be based on a relay station in lunar orbit, e.g. GATEWAY (LOP-G), and the WAIN. In case TRACTOR and WAIN are decoupled, a communication link between the two rovers will be established. Furthermore, a backup link between TRACTOR and relay station is foreseen, while providing limited bandwidth only.

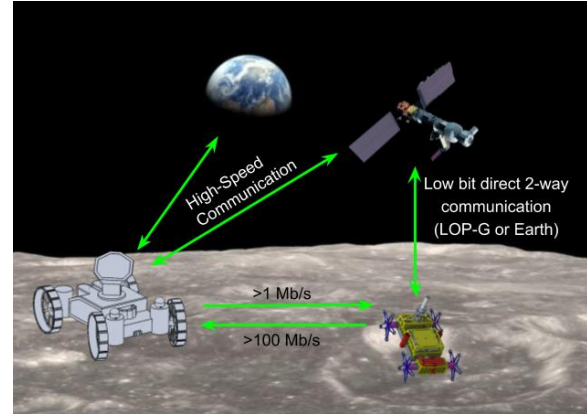

Figure 4: Schematic sketch of TRAILER communication architecture

The interfaces and interaction between the two rovers are highlighted in a general system breakdown of the TRAILER system, given in Figure 5.

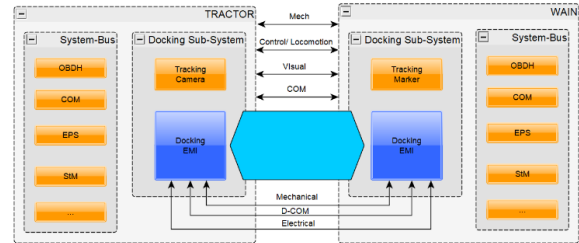

Figure 5: General System Breakdown of the Tandem Rover Assembly

A preliminary design of TRACTOR and WAIN is shown in Figure 6, highlighting the overall system dimensions. Compared to a theoretical overall system mass of 300 to 400 kg as derived from EXOMARS or HERACLES mission studies a scaling factor of $SM = 1:4$ is initially set for the design of the demonstrator platforms. Based on this, the scaling factor for system dimensions is given by $SD = SM(1/3)$. The mass distribution between the two rovers is preliminary also given by a factor of $MD = 1:4$, resulting a desirable mass for TRACTOR of up to 25 kg and for WAIN of up to 75 kg. In general, the factor should be as small as possible, meaning a mass shift towards WAIN while keeping the TRACTOR as lightweight as possible. The initial mass distribution is derived from the Coyote III [3] rover with a mass of approximately 15 kg. It serves as the baseline system for the TRACTOR design, while the dimensions are increased by 50%. Similar mass distributions are found e.g. for road trucks as well, gaining 40t mass in total with an 8t to 10t truck.

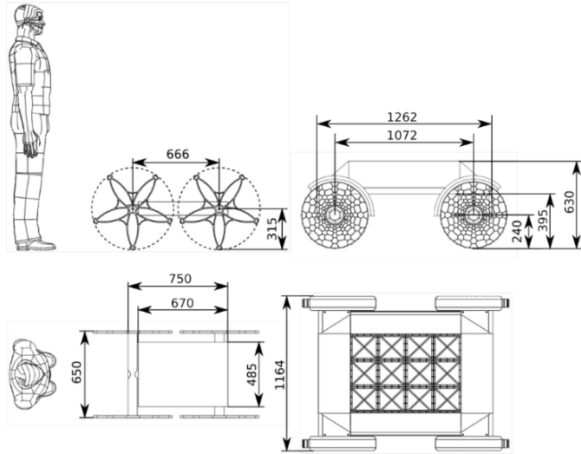

Figure 6: Size of TRACTOR and WAIN in comparison to a human for illustration purposes

3 LOADSHARING CONCEPT

For the locomotion behaviour of the coupled systems, the design and placement of the interface between them is crucial. To ensure that the TRACTOR can generate enough traction to move the (significantly heavier) WAIN, it is beneficial to distribute the cumulative mass of the coupled systems as evenly as possible among them. However, concepts where the gravity load is not distributed are also conceivable. Additionally, the number of DOF between the coupled systems may vary depending on the concept. If a configuration like an articulated truck or truck and trailer is employed, the coupling should allow both systems to change their orientation relative to each other. Thus, the coupled system is more adaptable to rough terrain, facilitating ground contact of each individual system. Another option is to have a stiff coupling between the systems. For this, steerable wheels, e.g. turntable steering or Ackermann steering on at least one system would be beneficial to ensure the manoeuvrability of the coupled system. Alternatively, if both systems employ skid steering, they could be coupled such that at least one axle of each system coincides with one of the other. This would reduce the wheelbase of the coupled system and facilitate skid steering in coupled configuration. Sharing no gravity load between the systems will reduce the traction of the TRACTOR in coupled mode and thus the amount of power it can transmit to the ground. Since this reduces the surplus driving force the TRACTOR can produce for pulling or pushing, solutions without gravity load sharing are not favoured. This includes concepts with redundant, passive, rotational DOF about the lateral axis in the coupling since it would counteract the transmission of vertical loads.

A set of alternative docking and load sharing concepts as sketched in 7 has been evaluated. Due to the outlined needs, connector design considerations and system complexity ‘Option 4’, where the systems are connected via a boom and the front wheels of the WAIN can be lifted was chosen as design base line. Thus, a part of the WAIN’s weight is carried by the TRACTOR and contributes in generating friction. To ensure steerability and adaptability to rough terrain, the interface should supply at least two non-redundant rotational DOF (up/down and left/right).

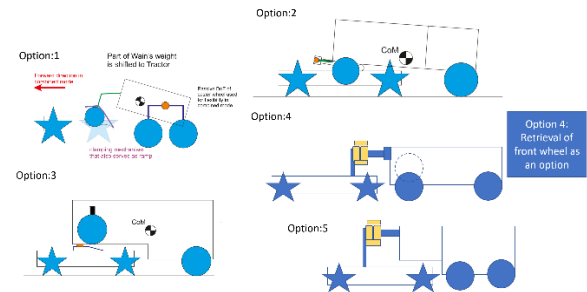

Figure 7: Alternative docking and load sharing concepts for TRACTOR and WAIN

5 TRACTOR DESIGN

The general TRACTOR design is based on DFKI’s COYOTE and ASGUARD highly mobile micro rover family [3][4][5]. Hence, a star-wheeled rover with four driven, non-steerable wheels is the baseline for the design. In terms of locomotion and traction performance the general idea is to equip the system with four directly driven hybrid legged wheels which are mounted on a flat and centered body structure. The general design idea of the TRACTOR rover is given in Figure 5. It is based on a largely symmetric design to gain high ground clearance and a compact but maximized support polygon while keeping the center of mass as low as possible. This ensures versatility, stability and robustness in rough terrain. For the ease of the lab-demonstrator it is envisioned to implement multi-purpose connection rails on top of the rover’s body, which would serve as a mounting point for the camera payload as well as the docking connector for the TRACTOR-WAIN tandem.

A conceptual flight design of the TRACTOR rover is based on the following sub-systems: i) structure and mechanisms (with housing, chassis, locomotion system), ii) on-board data handling (with on-board computer, data handling, housekeeping, data distribution, data processing), iii) communications (with telemetry and telecommand link to WAIN and back-up to MCC), iv) electrical power supply (with power management, battery management, power distribution,

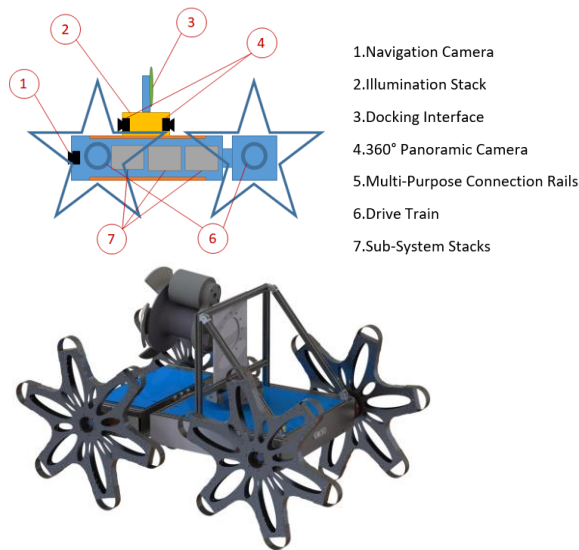

Figure 8: TRACTOR general system layout and bread-board design

solar array), v) thermal control system (with thermal control, thermal monitoring), vi) navigation subsystem (with navigation sensors, autonomy and planning, docking operations) and vii) payload subsystem(s) (with electro-mechanical docking interface, marker tracking, 360° panorama camera, illumination rig). Regarding mass and size estimations, the scaling factors as given above are used to scale the bread-board accordingly. Most of the sub-systems are incorporated in the bread-board design of the TRACTOR platform as well. Besides the fact, that the bread-board's sub-systems are based on industry rated COTS, a main difference is given in the COM and EPS sub-systems. For communications, the flight system must satisfy the overall communication architecture, as discussed previously. This means, a wireless communication link between TRACTOR and WAIN has to be established and coordinated with a wired connection while docked. Furthermore, a backup link is foreseen to enable the establishment of a back-up communication link to MCC in case the communication between TRACTOR and WAIN fails. Regarding EPS a solar array might be considered for the TRACTOR flight design as shown in Figure 9.

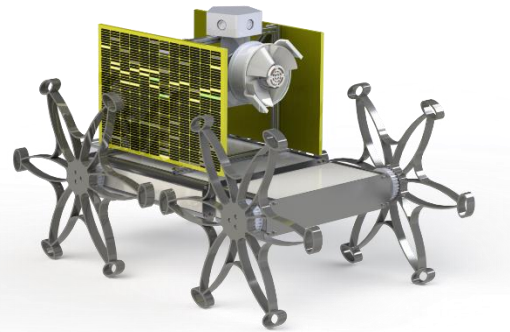

Figure 9: Artist's view of the TRACTOR flight model with potential solar array mountings

5.1 Data handling architecture

The data handling architecture of the TRACTOR rover follows a distributed processing concept, as outlined in Figure 10. While a central on-board computer is implemented to take care of the high-level processes, especially during autonomous operations, as during the docking process, an additional payload data handling subsystem is implemented for pre-processing of the data. Furthermore, a separate locomotion control unit is introduced to control the locomotion behavior and provide the motion commands to the motor controllers, which are running the four individual driving motors.

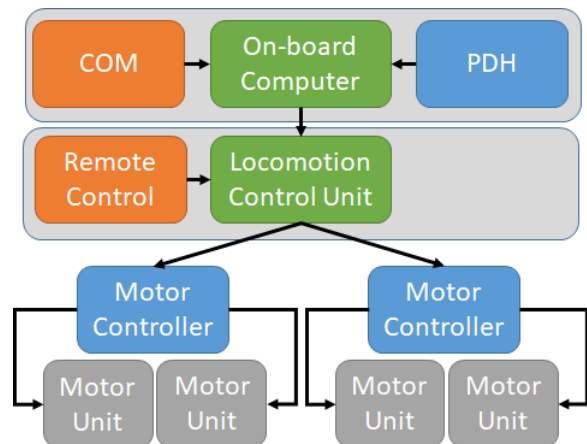

Figure 10: Schematic overview of TRACTOR's data handling architecture

The outlined configuration allows to implement complex locomotion and/or walking behaviours on a low control level. This is of interest, as the rover has potentially to change its locomotion behaviour, depending on its operational mode. Furthermore, a remote-controlled operation is possible without active on-board computer, which is handy for setting up different evaluation tests in the laboratory. For ground

controlled and/or autonomous operations, the onboard computer takes over the control and is providing the driving commands to the locomotion control unit

5.2 Docking Procedure

The TRAILER system is designed to operate in two different modes: i) the individual system operation, i.e. when TRACTOR and WAIN are operating without physical connection and ii) the coupled mode operation, i.e. when both are physically connected. To change between these modes an autonomous docking procedure will be executed. Overall the docking procedure requires the following main steps (i) both systems are separated but within range of optical markers, (ii) a coarse trajectory for TRACTOR is calculated and executed, (iii) re-evaluation of relative pose and fine approach, (iv) active alignment improvement of interfaces through WAIN pitch control, (v) blind approach for final mating.

6 WAIN DESIGN

The WAIN is a development performed by COMEX and the rover concept is not based on an existing platform. As described above, the WAIN serves as communication relay for the TRACTOR, as “recharging station” (thus carrying higher battery capacity) and for soil sample receiving and analysing. The objective was to develop a rover platform that is modular in design: Figure 11 below shows the chassis of WAIN which consists of a number of functional cubes (for example batteries or specific payload) that can be recombined like units of cubesats.

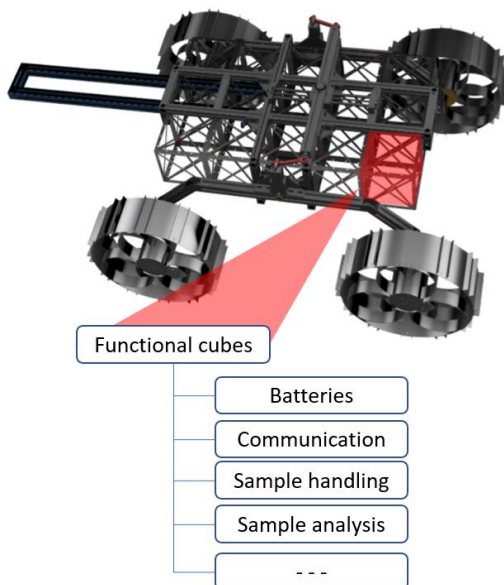

Figure 11: Modular chassis of the WAIN

The current mass estimation of the system without payload is 71,65kg. The locomotion train is based on a bogie concept in order to achieve the required capabilities to overcome obstacles. Figure 12 below shows the cinematics in a simplified manner. Each wheel disposes of its own motor-drive.

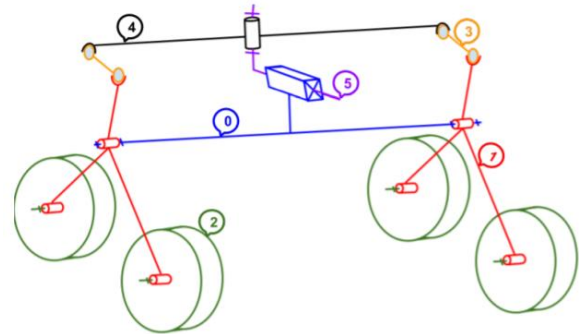

Figure 12: Cinematics of the WAIN rover

Various wheel architectures were taken into account such as rigid wheels [6] (e.g. NASA’s CURIOUSITY rover), deformable wheels [7] (e.g. EXOMARS from ESA) or Spring Tires [8] (e.g. APOLLO LRV). For WAIN deformable wheels, such as in EXOMARS have been chosen because such system does not require a suspension and therefore mass can be spared.



Figure 13: Different wheel types: (left) rigid, (center) deformable and (right) spring tire.

The WAIN wheel will be based on inox 304L with an outer diameter of 500mm and a width of 160mm. The motor-drives are integrated inside the wheel axle. Figure 14 below shows the architecture of WAIN’s wheels and FEM simulations. The maximal constraint of 115,8 MPa is below the elastic limit of the material. The maximal deformation is 2,5mm.

At the edition of this paper the development of the WAIN rover is at the stage of payload and subsystems integration into the CAD model. The finalisation of the system before testing is planned for January 2021. It will feature a dust-resistant docking and connection concept which will be tested in the facilities described in the following section.

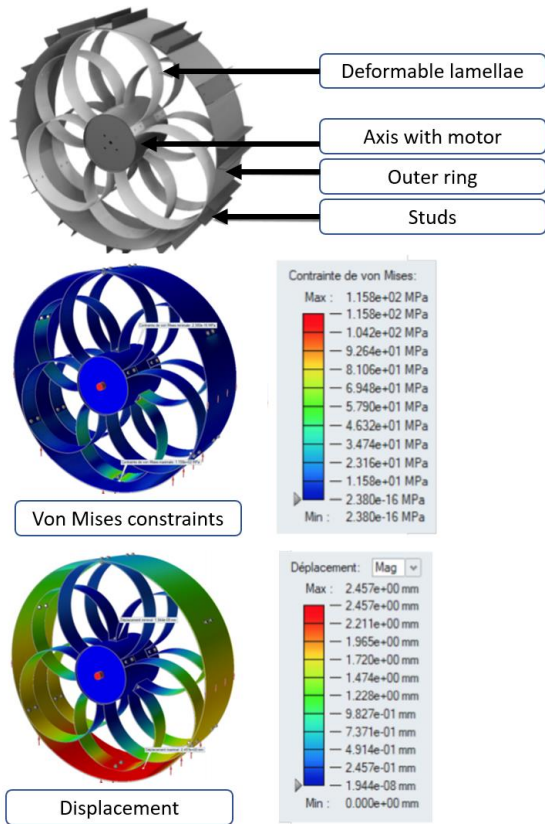

Figure 14: (top) Design of the deformable wheels of WAIN. (middle) Von Mises constraint analysis and (bottom) deformation.

6 TEST STRATEGY

The proposed test strategy that the TRAILER system will undergo includes several steps like laboratory tests of each robot at their respective “home” (DFKI in Germany and COMEX in France), outdoor tests in the DFKI Robot Test Track and an analogue site not far from COMEX. A specific test facility to evaluate the performance of the wheels in different slope angles will be developed. A concept view of this facility is shown in Figure 15. EAC-1 simulant will be used for these trials.

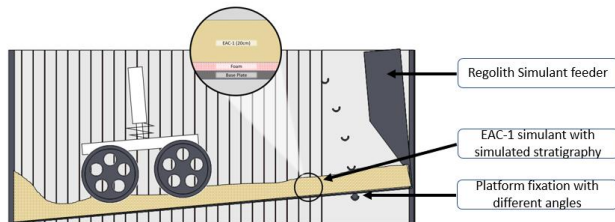

Figure 15: Current design of the wheel testbed

A combined test is planned with the DFKI Space Exploration Hall and the COMEX HYDROSPHERE at the end of the project. The DFKI Space Explora-

tion Hall allows the test and validation of robotic operations in a simulated lunar terrain (Figure 16). COMEX HYDROSPHERE (Figure 17) is a habitat simulator with an annex 5m diameter “dirty” vacu-
me chamber that is currently under development in another ESA project as Lunar Environment Surface Simulator (ESA Contract No. 4000130476/20/NL/CRS). In the frame of TRAILER, HYDROSPHERE will serve as GATEWAY simula-
tor.



Figure 16: (DFKI Space Exploration Hall

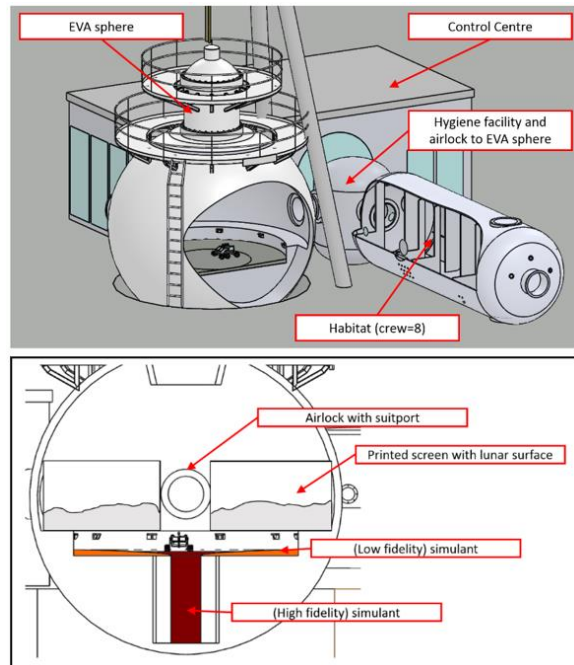

Figure 17: COMEX HYDROSPHERE Lunar Surface Simulator

5 CONCLUSION

Within this paper the preliminary design of the TRAILER system is described. The developments are based on the beforehand identified and formulated mission and system requirements as well mission

scenario definitions. The TRAILER system consists of two independent rovers, TRACTOR and WAIN, which are able to dock to each other and form a new unit. An overview of the general TRAILER system is given and the alteration of the design parameters for the breadboard design is addressed. The docking and load sharing capability between the two systems, is one of the key design drivers. Closer look has been taken on the docking and load sharing aspect for system operations as well as on the design of an electro-mechanical docking connector. Furthermore, the preliminary breadboard design considerations and definitions are presented, providing a consolidated description of both systems. The design of the TRAILER system is completed by a preliminary operational concept, describing the operations of the systems in single mode, as well as in combined mode. As a key aspect, the procedure for autonomous docking is outlined.

The proposed architecture could be iterated to other robotic operations, as shown in Figure 18: The docking system could be used to service science instruments on the lunar surface, as recharging station for long-duration robotic operations on the surface or the combination of a larger number of vehicles.

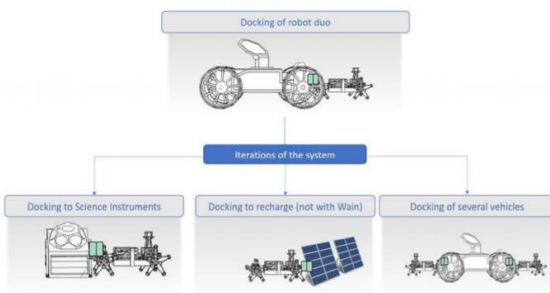

Figure 18: Future possible iterations of the concept.

Acknowledgement

The TRAILER project is financed by the European Space Agency ESA under the contract No 4000128049/19/NL/RA.

References

- [1] Forgotten Soviet Moon Rover Beams Light Back To Earth, IEEE Spectrum retrieved from <https://spectrum.ieee.org/aerospace/robotic-exploration/forgotten-soviet-moon-rover-beams-light-back-to-earth/0>
- [2] Landgraf, Carpenter and Sawada (2015) HERACLES concept- an international lunar exploration architecture study, Annual Meeting of the Lunar Exploration Analysis Group, retrieved from <https://www.hou.usra.edu/meetings/leag2015/presentations/Tuesday/1100-Landgraf.pdf>
- [3] DFKI (2020) Coyote III, Highly Mobile and Modular Micro Rover for Cooperative Tasks, retrieved from https://robotik.dfkibremen.de/uploads/tx_dfkiprojects/Systemblatt_CoyoteIII_en.pdf
- [4] Eich, M., Grimminger, F., Bosse, S., Spennberg, D., and Kirchner, F., (2008) Asguard: A hybrid legged wheel security and sar-robot using bio-inspired locomotion for rough terrain, In IARP/EURON Workshop on Robotics for Risky Interventions and Environmental Surveillance (IARP/EURON-08), 2008.
- [5] Sonsalla R., Bessekon Akpo J., Kirchner F.; (2015) Coyote III: Development of a Modular and highly Mobile Micro Rover, In Proceedings of the 13th Symposium on Advanced Space Technologies in Robotics and Automation (ASTRA-2015), (ASTRA-2015), Noordwijk, The Netherlands, ESA, May/2015. ESA.
- [6] R. E. Arvidson et al. (2017) Relating geologic units and mobility system kinematics contributing to Curiosity wheel damage at Gale Crater, Mars ». In : Journal of Terramechanics. Manned/Unmanned Ground Vehicles : Off-Road Dynamics and Mobility 73 (2017), p. 73-93. issn : 0022-4898.
- [7] P Poulakis et al. (2015), Overview and Development Status of the ExoMars Rover Mobility Subsystem, Conference: ASTRA 2015 - 13th ESA Workshop on Advanced Space Technologies for Robotics and Automation, Noordwijk, The Netherlands.
- [8] Raven B., (2019) NASA's new titanium, elastic tire could help rovers travel farther on Moon, Mars, retrieved from https://www.mlive.com/news-us-world/2017/11/nasas_new_tires.html